

CE 642

Biogas plant



The illustration shows from left to right: supply unit, trainer and post-fermentation unit; screen mirroring is possible on different end devices

Description

- two-stage biogas plant
- extensive biogas analysis
- plant control using a PLC via touch screen
- integrated router for operation and control via an end device and for screen mirroring on additional end devices: PC, tablet, smartphone

In a biogas plant, microorganisms biologically degrade the organic starting substances (substrate) under exclusion of light and oxygen. The product of this anaerobic degradation is a gas mixture which primarily consists of methane. This gas mixture is called biogas.

The experimental plant CE 642 serves to demonstrate the generation of biogas in a practical manner. The substrate is a suspension of shredded organic solids. It is hydrolysed and acidified in the first stirred tank reactor. Here, anaerobic microorganisms convert the long-chain organic substances into short-chain organic substances. The biogas forms in the second stirred tank reactor in the last step of the anaerobic degradation. It contains mainly methane and carbon dioxide. This two-stage method enables the ambient conditions to be adjusted and optimised in both reactors separately. The digestate is collected in a separate tank.

Temperature and pH value are controlled in both reactors. The resulting biogas is dried in a column. The column is filled with silica gel. Subsequently, the flow rate, humidity, methane content, carbon dioxide content and temperature of the biogas are measured. The system is controlled by the PLC via touch screen. By means of an integrated router, the system can alternatively be operated and controlled via an end device. The user interface can also be displayed on additional end devices (screen mirroring). Via the PLC, the measured values can be stored internally. Access to stored measured values is possible from end devices via WLAN with integrated router/LAN connection to the customer's own network.

The experimental plant enables both a continuous and a discontinuous (batch) operation mode. Anaerobic biomass from a biogas plant is required for the experiments. E.g. potatoes or maize can be used to produce the substrate. An inert gas (e.g. carbon dioxide) is required to flush the experimental plant.

Learning objectives/experiments

- achieving a stable operating state
- influence of the following parameters on the biogas generation
 - ▶ temperature
 - ▶ substrate
 - ▶ volumetric loading
 - ▶ pH value
- influence of the operation mode on the biogas yield
 - ▶ single stage or dual stage
 - ▶ with and without post-fermentation
 - ▶ continuous and discontinuous
- determining the following parameters depending on the operating conditions
 - ▶ biogas yield
 - ▶ biogas flow rate
 - ▶ biogas quality
- screen mirroring: mirroring of the user interface on end devices
 - ▶ menu navigation independent of the user interface shown on the touch screen
 - ▶ different user levels available on the end device: for observing the experiments or for operation and control

CE 642

Biogas plant

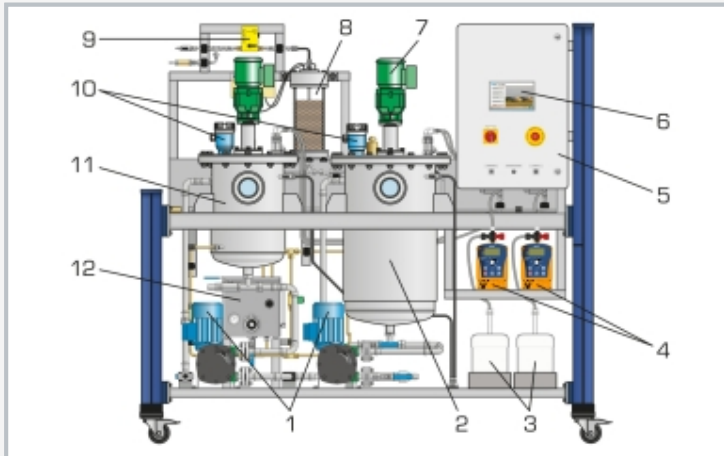

1 peristaltic pumps, 2 reactor (stage 2), 3 tanks for acid and caustic, 4 metering pumps, 5 switch cabinet, 6 PLC with touch screen, 7 stirring machine, 8 drying column, 9 flow meter (biogas), 10 capacitive level sensors, 11 reactor (stage 1), 12 heating water tank

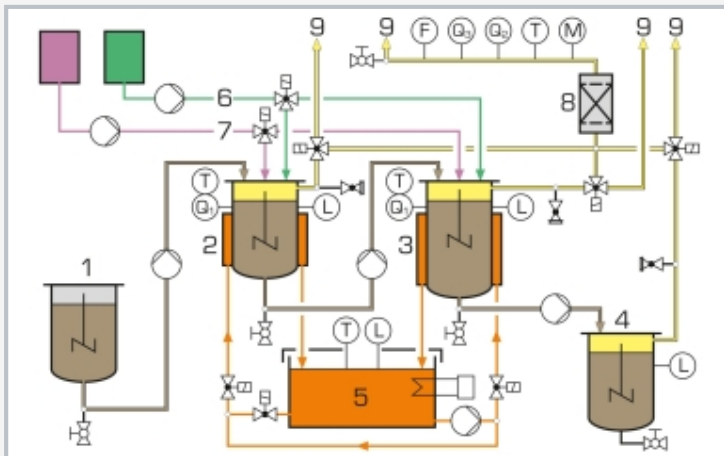

1 substrate tank, 2 reactor (stage 1), 3 reactor (stage 2), 4 digestate tank, 5 heating water, 6 acid, 7 caustic, 8 drying column, 9 biogas; F flow rate, L level, M humidity, Q₁ pH value, Q₂ methane content, Q₃ carbon dioxide content, T temperature

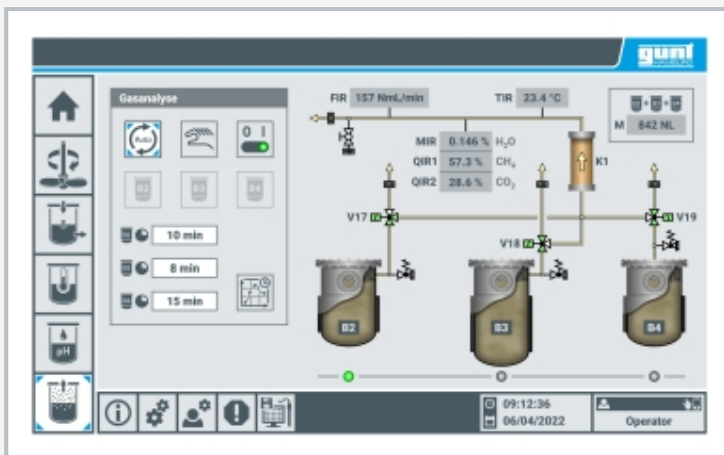

Operating interface of the PLC: menu item "gas analysis"

Specification

- [1] two-stage biogas plant (continuous or discontinuous operation possible)
- [2] 2 stirred tank reactors made of stainless steel with capacitive level sensors
- [3] separate supply unit with substrate tank and feed pump
- [4] control of temperature and pH value in the reactors
- [5] 2 metering pumps for acid and caustic
- [6] heating water circuit with tank, heater, temperature controller and pump
- [7] biogas is dried with silica gel
- [8] biogas analysis: flow rate, methane content, carbon dioxide content, humidity and temperature
- [9] plant control with PLC via touch screen
- [10] integrated router for operation and control via an end device and for screen mirroring: mirroring of the user interface on up to 5 end devices
- [11] data acquisition via PLC on internal memory, access to stored measured values via WLAN with integrated router/ LAN connection to customer's own network

Technical data

PLC: Eaton XV303

Tanks made of stainless steel

- reactor (stage 1): 26,3L
- reactor (stage 2): 73,5L
- substrate tank: approx. 30L
- digestate tank: 26,3L

Pumps

- 3 peristaltic pumps: each max. 25L/h
- 2 metering pumps: each max. 2,1L/h
- heating water pump: max. 480L/h

Stirring machines

- substrate tank: max. 200min⁻¹
- reactors: each max. 120min⁻¹

Measuring ranges

- methane content: 0...100%,
- carbon dioxide content: 0...100%
- flow rate: 0...30NL/h (biogas)
- pH value: 2x 1...14
- humidity: 0...100%
- temperature: 3x 0...100°C (reactors and biogas)

400V, 50Hz, 3 phases; 400V, 60Hz, 3 phases

230V, 60Hz, 3 phases; UL/CSA optional

LxWxH: 1100x790x1400mm (supply unit)

LxWxH: 2060x790x1910mm (trainer)

LxWxH: 1100x790x1400mm (post-fermentation unit)

Total weight: approx. 770kg

Required for operation

biomass from a biogas plant, substrate (recommendation: potatoes or maize), caustic soda, hydrochloric acid, inert gas (e.g. carbon dioxide) 5kg/h, min. 2bar; water connection + drain 300L/h, min. 3bar; exhaust air + ventilation 245m³/h

Scope of delivery

- 1 experimental plant, 1 packing unit of silica gel
- 1 set of accessories, 1 set of instructional material